

FIXED ULTRA BOW ROLLER

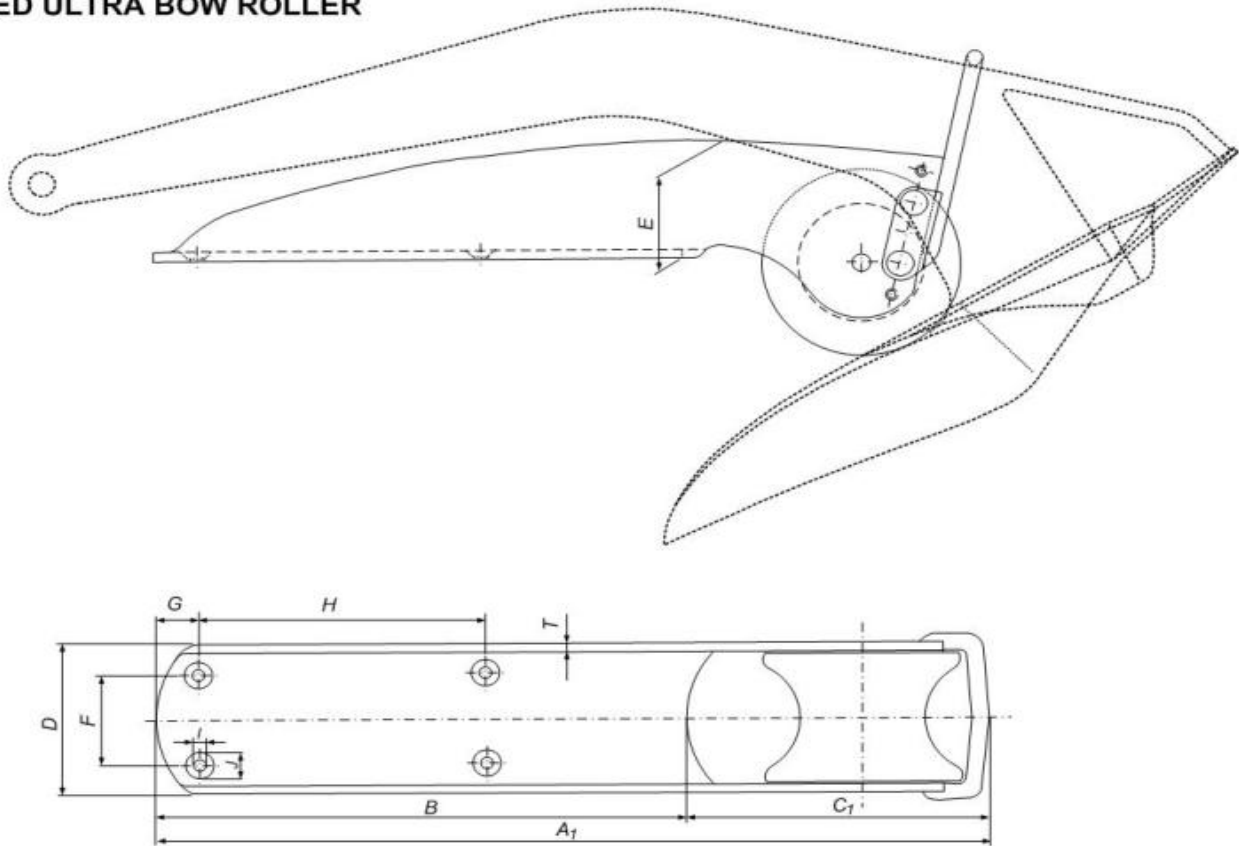

| ANCHOR (kg) | | 8 | 12 | 16 | 21 | 27 | 35 | 45 | 60 | 80 | 100 | 130 | 160 | 200 |
|--------------|----------|-------|-------|-------|-------|-------|-------|-------|--------|--------|--------|--------|--------|--------|
| A1 | S | 285.9 | 327.3 | 360.2 | 394.4 | 428.9 | 467.6 | 508.5 | 559.6 | 616.0 | 663.5 | 724.2 | 776.1 | 836.0 |
| | M | 375.5 | 429.8 | 473.1 | 518.0 | 563.3 | 614.1 | 667.8 | 735.0 | 809.0 | 871.5 | 951.1 | 1019.3 | 1098.0 |
| | L | 518.9 | 594.0 | 653.8 | 715.8 | 778.4 | 848.7 | 922.8 | 1015.7 | 1117.9 | 1204.3 | 1314.3 | 1408.5 | 1517.3 |
| B | S | 149.4 | 171.0 | 188.2 | 206.1 | 224.1 | 244.3 | 265.7 | 292.4 | 321.9 | 346.7 | 378.4 | 405.5 | 436.8 |
| | M | 239.0 | 273.6 | 301.1 | 329.7 | 358.5 | 390.9 | 425.0 | 467.8 | 514.9 | 554.7 | 605.4 | 648.7 | 698.8 |
| | L | 382.4 | 437.7 | 481.8 | 527.5 | 573.6 | 625.4 | 680.1 | 748.5 | 823.9 | 887.5 | 968.6 | 1038.0 | 1118.1 |
| C1 | | 136.5 | 156.3 | 172.0 | 188.3 | 204.8 | 223.3 | 242.8 | 267.2 | 294.1 | 316.8 | 345.7 | 370.5 | 399.1 |
| D | | 72.6 | 83.1 | 91.5 | 100.1 | 108.9 | 118.7 | 129.1 | 142.1 | 156.4 | 168.5 | 183.9 | 197.1 | 212.3 |
| E | | 58.0 | 66.4 | 73.1 | 80.0 | 87.0 | 94.9 | 103.1 | 113.5 | 125.0 | 134.6 | 146.9 | 157.4 | 169.6 |
| F (*) | | | | | | | | | | | | | | |
| G (*) | | | | | | | | | | | | | | |
| H (*) | | | | | | | | | | | | | | |
| I (*) | | 7.0 | 7.0 | 7.0 | 9.5 | 9.5 | 11.5 | 11.5 | 11.5 | 14.0 | 14.0 | 14.0 | 16.0 | 16.0 |
| J (*) | | 13.0 | 13.0 | 13.0 | 17.2 | 17.2 | 21.5 | 21.5 | 21.5 | 26.0 | 26.0 | 26.0 | 29.0 | 29.0 |
| T | | 4.0 | 4.0 | 4.0 | 5.0 | 5.0 | 6.0 | 6.0 | 6.0 | 8.0 | 8.0 | 8.0 | 10.0 | 10.0 |

(*) : Dimensions are in mm.

(*) : The bow roller chassis is manufactured without holes to be drilled by customer or it is manufactured with pre-drilled and counter sunk holes if the dimensions of "F,G,H" are provided with order



Offices:
 Quickline USA
 8700 Warner Ave #110
 Fountain Valley, CA 92708

714-843-6964
 714-843-6906 FAX
 sales@quickline.us